

REF. 3.226

IZ-DW155 Aparador

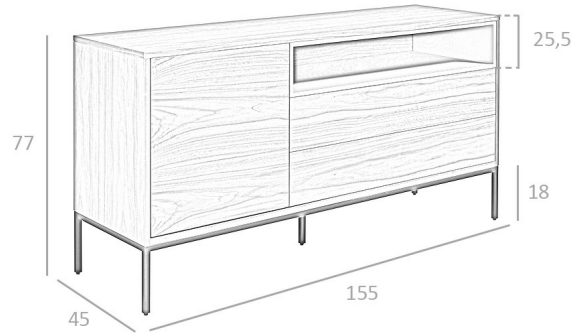

MEDIDAS

Medidas: 155 x 45 x 77 cm.

Peso: 69 Kg.

EMBALAJE

161 x 51 x 63 cm. / 51 Kg.

161 x 51 x 25 cm. / 22 Kg.

VOLUMEN

0,72 m3

PRODUCTO

Chapa Nogal / DM Lacado Similar R7030

Mate

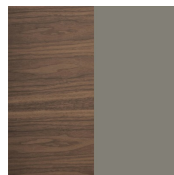

PATAS

Material Patas: Acero color Negro

