

REF. 4.093

DC1599 Silla

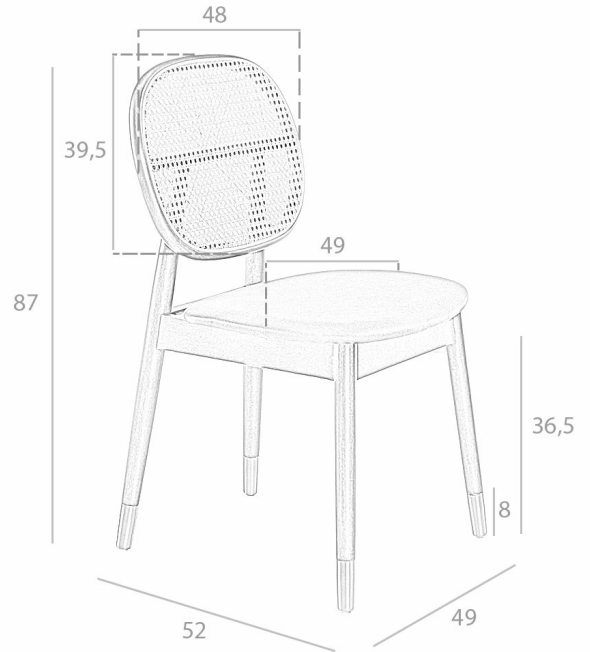

MEDIDAS

Medidas: 49 x 52 x 87 cm.

Peso: 7 Kg.

EMBALAJE

62 x 45 x 96 cm. / 16 Kg.

VOLUMEN

0,13 m3

PRODUCTO

Polipiel - Stock - Similar Acua 90

Rattan

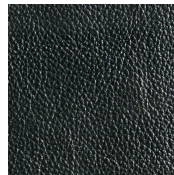

PATAS

Material Patas: Madera color Nogal

