

**REF. 5.082**

**LC17088 Sillón tapizado**

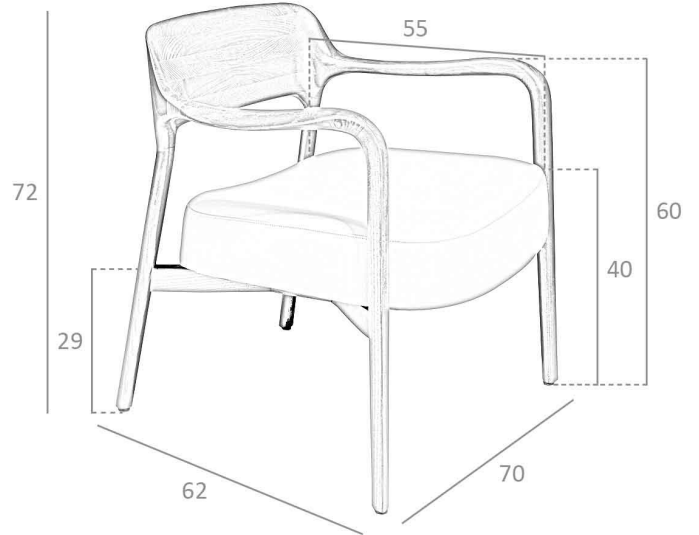

**MEDIDAS**

Medidas: 70 x 62 x 72 cm.

Peso: 7 Kg.

**EMBALAJE**

75 x 68 x 77 cm. / 8 Kg.

**VOLUMEN**

0,44 m3

**PRODUCTO**

Polipiel - STOCK - Similar Acua 18

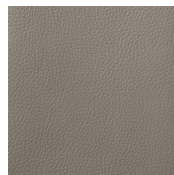

**PATAS**

Material Patas: Madera Fresno color Nogal

